



**D SERIES - OIL FIRED**  
**DG SERIES - GAS FIRED**

**COMPACT, SPACE SAVING DESIGN**

**SPACE HEATING UP TO 15 PSI**

**PROCESS STEAM UP TO 15 PSI**

**VERTICAL FIRETUBE BOILER**

**CAPACITIES: 115 – 1,400 MBH**

**80 - 83% EFFICIENCY**

**GAS • OIL**

**THERMAL SHOCK PROOF DESIGN**

**WATER BACKED COMBUSTION CHAMBER**

**EASY ACCESS TO BURNER**

**BUILT/CERTIFIED TO ASME CODE**



# **D & DG SERIES**

## **15 PSI STEAM BOILERS**



The "D & DG" include a low stress thermal shock resistant single pass vertical design. With thousands of boilers installed worldwide this has proven to be a robust boiler design.

Primary flue gases pass via water backed heat transfer tubes. No refractory backed finned passages to burn out.

Large steam chamber with internal water separator insures high quality dry steam.

The "D & DG" Series may be factory constructed with an integral copper finned heat exchanger allowing the boiler the ability to provide both direct heating and indirect heating.



The forte of Aldrich Company has always been to only manufacture products of the highest quality and design, by using the finest materials available and employing loyal craftsmen with the skills and aptitude necessary towards this end. We outsource no sub-assemblies and we procure only domestic steel and tubing to fabricate our pressure vessels. All Aldrich boilers and water heaters are constructed and stamped to Section IV of the ASME code and registered with the National Board of Pressure Vessel Inspectors.

### BOILER RATINGS & DIMENSIONS - "D" OIL FIRED - "DG" GAS FIRED

MODEL: D / DG	130	160	220	280	360	450	530	610	730	890	900	1000	1250
Gas Input (MBH)	144	180	248	315	405	495	585	675	810	990	1,148	1,350	1,750
Oil Input (GPH)	1.1	1.3	2.0	2.5	3.0	4.0	4.5	5.0	6.0	7.5	9.0	10.0	12.5
Output (MBH)	115	144	198	252	324	396	468	540	648	792	936	1,080	1,400
Output (Horsepower)	3.4	4.3	5.9	7.5	9.7	11.8	14.0	16.1	19.4	23.7	28.0	32.3	41.8
Htg Surf. FS (Sq Ft)	19	24	32	41	53	65	77	88	106	129	153	177	216
Shipping Weight (LBS)	690	810	1,040	1,090	1,365	1,475	1,635	1,765	2,005	2,270	2,650	3,510	3,932
<b>A</b> Width	23	25	29	29	32	32	34	36	40	42	42	48	48
<b>B</b> Height	49½	54	57½	61½	67	70	71	72½	72½	76	80	80	80
<b>C</b> Overall Length	35	37	41	41	44	44	46	48	52	60	60	66	66
<b>D</b> Return Size (NPT)	2	2	2½	2½	2½	2½	2½	3	3	3	3	3	3
<b>E</b> Return Height	6	6	6	6	6	6	6	6	6	6	6	6	6
<b>F</b> Supply Size (NPT)	2	2	2½	2½	2½	2½	2½	3	3	3	3	3	3
<b>G</b> Supply Location	8¼	9½	11	11	12½	12½	13½	14¼	16	17¼	17¼	20	20
<b>H</b> Burner Port Height	12	12	12	12	12	12	12	12	16	16	16	16	16
<b>J</b> Flue Size	6	7	8	8	9	9	9	9	10	10	12	12	12

ALL DIMENSIONS ARE IN INCHES. DIMENSIONS SUBJECT TO CHANGE WITHOUT NOTICE. CERTIFIED DRAWING AVAILABLE UPON REQUEST.

BOILERS MAY BE PROVIDED WITH FACTORY INSTALLED COPPER FINNED TANKLESS COILS FOR INDIRECT HEATING. CONSULT FACTORY FOR SIZING.

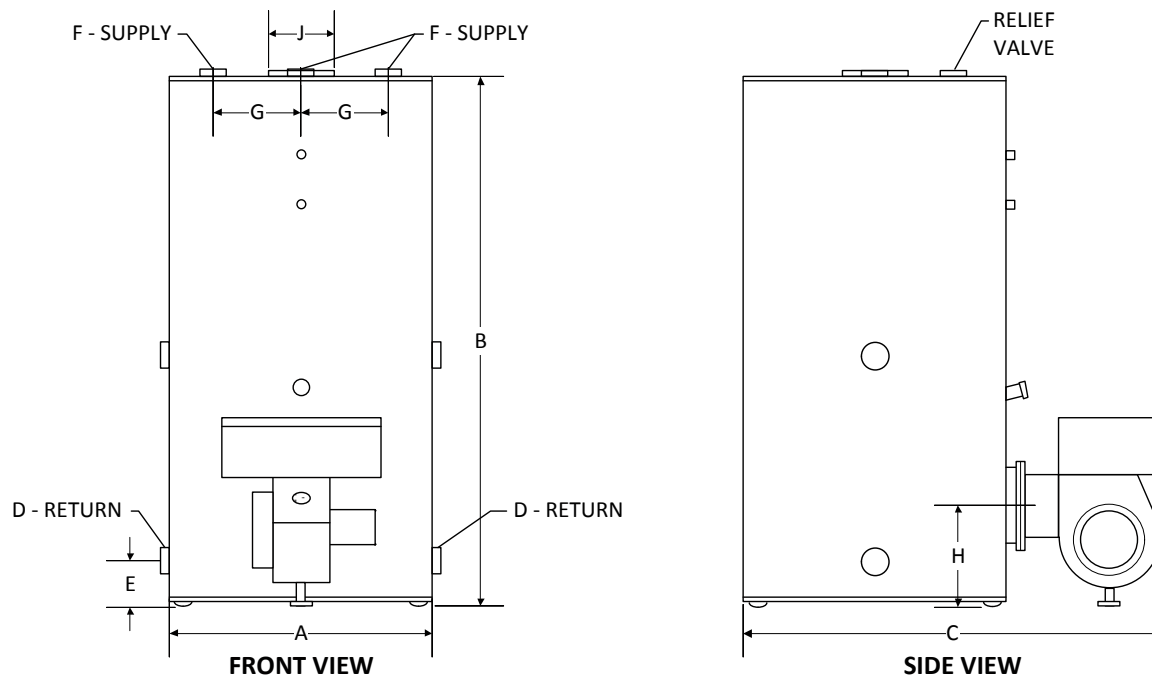

**QUALITY • PERFORMANCE • EFFICIENCY • EXPERIENCE**

ALDRICH COMPANY • 341 EAST WILLIAMS STREET, P.O. BOX 97 • WYOMING, IL 61491 • TEL: 309-695-2311 • FAX: 309-695-5779